

# **MENIIT**

**NEET | IIT-JEE | FOUNDATION**

**Corporate Office:** 44-A/1, Kalu Sarai, New Delhi 110016 | **Web:** [www.meniit.com](http://www.meniit.com)

## **JEE MAIN-2022**

### **COMPUTER BASED TEST (CBT)**

**DATE : 27-06-2022 (EVENING SHIFT) | TIME : (3.00 PM to 6.00 PM)**

**Duration 3 Hours | Max. Marks : 300**

**QUESTIONS  
&  
SOLUTIONS**

**PART : PHYSICS**

1. The SI unit of a physical quantity is pascal-second. The dimensional formula of this quantity will be :  
 (A)  $[ML^{-1}T^{-1}]$  (B)  $[ML^{-1}T^{-2}]$  (C)  $[ML^2T^{-1}]$  (D)  $[ML^{-1}L^3T^0]$

**Ans. A**

**Sol.**  $PT = \frac{Ft}{A} = \frac{\text{Change in momentum}}{\text{Area}}$

$$\frac{MLT^{-1}}{L^2} = ML^{-1}T^{-1}$$

2. The distance of the Sun from earth is  $1.5 \times 10^{11}m$  and its angular diameter is (2000) s when observed from the earth. The diameter of the Sun will be :

- (A)  $2.45 \times 10^{10}m$  (B)  $1.45 \times 10^{10}m$  (C)  $1.45 \times 10^9m$  (D)  $0.14 \times 10^9m$

**Ans. C**

**Sol.**

$$1 \text{ min} = 60s$$

$$1^\circ = 60 \text{ min}$$

$$1^\circ = 3600 \text{ sec}$$

$$2000s = \frac{1}{3600} \times 2000 \text{ degree}$$

$$\frac{20}{36} \text{ degree} = \frac{\pi}{180} \times \frac{20}{36} \text{ rad}$$

$$D = r\theta = 1.5 \times 10^{11} \times \frac{\pi}{180} \times \frac{20}{36}$$

$$= \frac{1.5\pi}{18^2} \times 10^{11}$$

$$= 0.0145 \times 10^{11}$$

$$= 1.45 \times 10^9$$

3. When a ball is dropped into a lake from a height 4.9m above the water level, it hits the water with a velocity  $v$  and then sinks to the bottom with the constant velocity  $v$ . It reaches the bottom of the lake 4.0 s after it is dropped. The approximate depth of the lake is :

- (A) 19.6 m (B) 29.4m (C) 39.2m (D) 73.5m

**Ans. B**

**Sol.**

$$S = ut + \frac{1}{2}at^2$$

$$-4.9 = 0 + \frac{1}{2}(-9.8)t^2$$

$$t = 1 \text{ sec}$$

In 1 sec it reach the surface of water

$$V^2 = u^2 + 2as$$

$$V^2 = 0 + 2(-9.8)(4.9) \therefore v = 9.8$$

then in water journey =  $4 - 1 = 3 \text{ sec}$

$$h = vt = 9.8 \times 3 = 29.4 \text{ metre}$$

4. One end of a massless spring of spring constant  $k$  and natural length  $\ell_0$  is fixed while the other end is connected to a small object of mass  $m$  lying on a frictionless table. The spring remain horizontal on the table. If the object is made to rotate at an angular velocity  $\omega$  about an axis passing trough fixed, then the elongation of the spring will be :

- (A)  $\frac{k - m\omega^2 \ell_0}{m\omega^2}$  (B)  $\frac{m\omega^2 \ell_0}{k + m\omega^2}$  (C)  $\frac{m\omega^2 \ell_0}{k - m\omega^2}$  (D)  $\frac{k + m\omega^2 \ell_0}{m\omega^2}$

**Ans. C**

**Sol.**

For circular motion

$$Kx = m\omega^2(\ell_0 + x)$$

$$\Rightarrow (k - m\omega^2)x = m\omega^2 \ell_0$$

$$\Rightarrow x = \frac{m\omega^2 \ell_0}{k - m\omega^2}$$

5. A stone tied to a string of length  $L$  is whirled in a vertical circle with the other end of the string at the centre. At a certain instant of time, the stone is at its lowest position and has a speed  $u$ . The magnitude of change in its velocity, as it reaches a position where the string is horizontal, is  $\sqrt{x(u^2 - gL)}$ . The

value of  $x$  is –

**Ans. B**

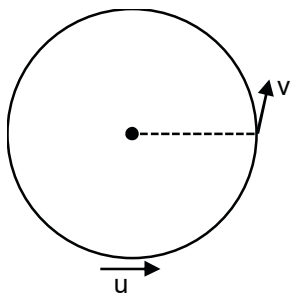

Sol.

$$-mg\ell = \frac{1}{2}mv^2 - \frac{1}{2}mu^2$$

$$v = \sqrt{u^2 - 2gl}$$

$$|\Delta v| = \sqrt{u^2 + u^2 - 2gl}$$

6. Four spheres each of mass  $m$  form a square of side  $d$  (as shown in figure). A fifth sphere of mass  $M$  is situated at the centre of square. The total gravitation potential energy of the system is :

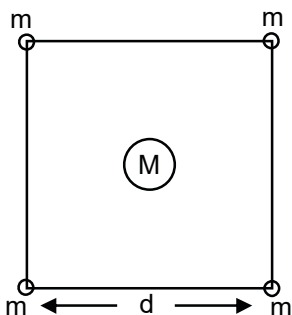

(A)  $-\frac{Gm}{d} [(4 + \sqrt{2})m + 4\sqrt{2}M]$

(B)  $-\frac{Gm}{d} [(4 + \sqrt{2})M + 4\sqrt{2}m]$

(C)  $-\frac{Gm}{d} [3m^2 + 4\sqrt{2}M]$

(D)  $-\frac{Gm}{d} [6m^2 + 4\sqrt{2}M]$

Ans. A

Sol.  $PE = -\left(\frac{4Gm^2}{d} + \frac{2Gm^2}{\sqrt{2}d} + \frac{4GmM}{d/\sqrt{2}}\right) = -\frac{Gm}{d} [4\sqrt{2}M + m(4 + \sqrt{2})]$

7. For a perfect gas, two pressures  $P_1$  and  $P_2$  are shown in figure, The graph shows :

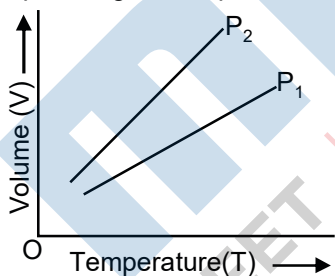

(A)  $P_1 > P_2$

(B)  $P_1 < P_2$

(C)  $P_1 = P_2$

(D) Insufficient data to draw any conclusion

Ans. A

Sol.  $PV = nRT$

$$V = \left(\frac{nR}{P}\right)T$$

8. According to kinetic theory of gases,  
 A. The motion of the gas molecules freezes at  $0^\circ\text{C}$ .  
 B. The mean free path of gas molecules decrease if the density of molecules is increased.  
 C. The mean free path of gas molecules increase if temperature is increased keeping pressure constant.  
 D. Average kinetic energy per molecules per degree of freedom is  $\frac{3}{2}k_B T$  (for monoatomic gases).

Choose the most appreciate answer from the option given below:

- (A) A and C only      (B) B and C only      (C) A and B only      (D) C and D only

Ans. B

**Sol.** Mean free path  $\lambda = \frac{1}{\sqrt{2}\pi d^2 n}$        $n = \frac{N}{V}$   
 $\Rightarrow \lambda = \frac{1}{\sqrt{2}\pi d^2 N/V}$        $PV = NKT$   
 $\Rightarrow \lambda = \frac{KT}{\sqrt{2}\pi d^2 P}$        $P = \frac{\rho RT}{M}$

9. A lead bullet penetrates into a solid object and melts. Assuming that 40% of its kinetic energy is used to heat it, the initial speed of bullet is :  
 (Given, initial temperature of the bullet = 127°C, Melting point of the bullet = 327°C, Latent heat of fusion of lead =  $2.5 \times 10^4$  J kg<sup>-1</sup>, Specific heat capacity of lead = 125J/kg K)  
 (A) 125 ms<sup>-1</sup>      (B) 500 ms<sup>-1</sup>      (C) 250 ms<sup>-1</sup>      (D) 600 ms<sup>-1</sup>

**Ans. B**

**Sol.**  $0.4 \times \frac{1}{2}mv^2 = mS(t_2 - t_1) + mL$

$v = 500$

10. The equation of a particle executing simple harmonic motion is given by

$x = \sin \pi \left( t + \frac{1}{3} \right) m$ . At  $t = 1$ s, the speed of particle will be

(Given :  $\pi = 3.14$ )–

- (A) 0 cm s<sup>-1</sup>      (B) 157 cm s<sup>-1</sup>      (C) 272 cm s<sup>-1</sup>      (D) 314 cm s<sup>-1</sup>

**Ans. B**

**Sol.**  $V = \frac{dx}{dt} = \pi \cos \pi \left( t + \frac{1}{3} \right)$

$V$  at  $t = 1 = \pi \cos \pi \left( 1 + \frac{1}{3} \right)$

$= \pi \cos \left( \pi + \frac{\pi}{3} \right)$

$= -\pi \cos \frac{\pi}{3}$

$= -\frac{\pi}{2}$

11. If a charge  $q$  is placed at the centre of a closed hemispherical non-conductivity surface, the total flux passing through the flat surface would be :

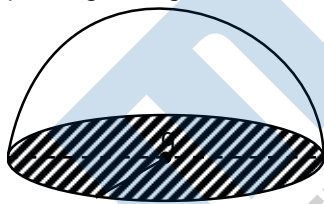

**Ans. Bonus**

**Sol. Flux should be zero**

12. Three identical charged balls each of charge 2 C are suspended from a common point P by silk threads of 2 m each (as shown in figure). They form an equilateral triangles of side 1m. The ratio of net force on a charged ball to the force between any two charged balls will be :

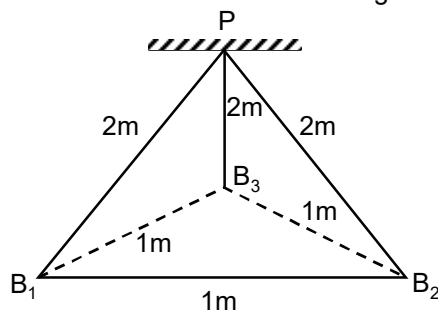

**Ans. D**

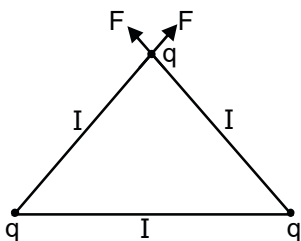

Sol.

Net force on are charge

$$F_q = \sqrt{F^2 + F^2 + 2FF \cos 60^\circ}$$

$$= \sqrt{3}F$$

Where F is forced b/w any two charges

$$\text{So } \frac{F_q}{F} = \sqrt{3}$$

13. Two long parallel conductors  $S_1$  and  $S_2$  are separated by a distance 10cm and carrying currents of 4A and 2A respectively. The conductors are placed along x – axis in X–Y plane. There is point P located between the conductors (as shown in figure).

A charge particle of  $3\pi$  coulomb is passing through the point P with velocity  $\vec{v} = (2\hat{i} + 3\hat{j})\text{m/s}$ ; where  $\hat{i}$  &  $\hat{j}$  respectively unit vectors along x & y axis respectively.

The force acting on the charge particle is  $4\pi \times 10^{-5}(-x\hat{i} + 2\hat{j})\text{N}$ . The value of x is :

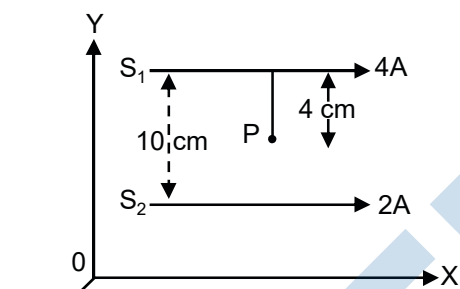

Ans.

(A) 2  
C

(B) 1

(C) 3

(D) -3

Sol.

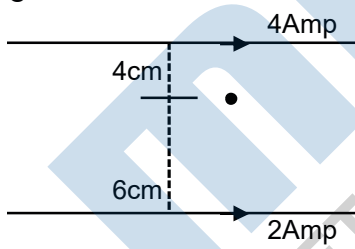

$$B_{\text{Net}} = \frac{\mu_0 4}{2\pi \times \frac{4}{100}} - \frac{\mu_0 2}{2\pi \times \frac{6}{100}}$$

$$= \frac{\mu_0}{\pi} \times 100 \left[ \frac{1}{2} - \frac{1}{6} \right]$$

$$= \frac{\mu_0}{\pi} \times 100 \left[ \frac{4}{2 \times 6} \right]$$

$$= \frac{\mu_0 \times 100}{3\pi} (-\hat{k})$$

$$\vec{F} = q(\vec{v} \times \vec{B}) = 3\pi [2\hat{i} + 3\hat{j}] \frac{\mu_0 \times 100}{3\pi} (-\hat{k})$$

$$= 4\pi \times 10^{-7} [2\hat{i} + 3\hat{j}] \times 100 (-\hat{k})$$

$$= 4\pi \times 10^{-5} [2\hat{j} - 3\hat{i}]$$

$$\therefore x = 3$$

14. If L, C and R are the inductance, capacitance and resistance respectively, which one of the following does not have the dimension of time ?

- (A) RC                      (B)  $\frac{L}{R}$                       (C)  $\sqrt{LC}$                       (D)  $\frac{L}{C}$

Ans. D

Sol. We know that time period is

$$T = 2\pi\sqrt{LC}$$

So  $\sqrt{LC}$  represents dimensions of time const. of L-R series circuit is  $\frac{L}{R}$  so  $\frac{L}{R}$  represent dimensions of time. Time const. of R-C circuit in RC so RC represents dimension of time  $\frac{L}{C}$  does not represent dimensions of time

15. Given below two statements :

Statement I : A time varying electric field is a source of changing magnetic field and vice-versa. Thus a disturbance in electric or magnetic field creates EM waves.

Statement II : In a material medium, the EM wave travels with speed  $v = \frac{1}{\sqrt{\mu_0 \epsilon_0}}$ . In light of the above

statements, choose the correct answer from the options given below.

- (A) Both statement I and statement II are true  
 (B) Both statement I and statement II are false  
 (C) Statement I is correct but statement II is false  
 (D) Statement I is incorrect but statement II is true

Ans. C

16. A convex lens has power P. It is cut two halves along its principle axis. Further one piece (out of the two halves) is cut into halves perpendicular to the principle axis (as shown in figures). Choose the incorrect option for the reported pieces.

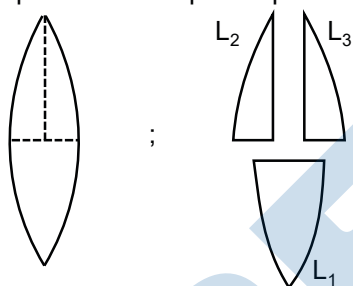

- (A) Power of  $L_1 = \frac{P}{2}$                       (B) Power of  $L_2 = \frac{P}{2}$   
 (C) Power of  $L_3 = \frac{P}{2}$                       (D) Power of  $L_1 = P$

Ans. A

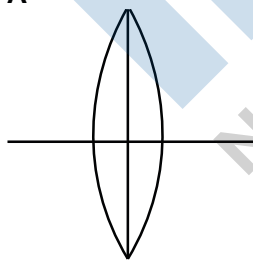

Sol.

$$P = \frac{1}{f} = (\mu - 1) \left( \frac{2}{R} \right)$$

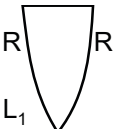

$$P_1 = \frac{1}{f} = (\mu - 1) \left( \frac{2}{R} \right) = P$$



$$P_2 = \frac{1}{f} = (\mu - 1) \left( \frac{1}{R} \right) = \frac{P}{2}$$



$$P_3 = \frac{1}{f} = (\mu - 1) \left( \frac{1}{R} \right) = \frac{P}{2}$$

17. If a wave gets refracted into a denser medium, then which of the following is true ?  
 (A) wavelength, speed and frequency decrease.  
 (B) wavelength increases, speed and frequency remains constant.  
 (C) wavelength increases, speed and frequency remains constant.  
 (D) wavelength, speed and frequency increases.

Ans. C

Sol.  $v = f\lambda$   
 $f = \text{constant}$   
 So,  $v \propto$

In denser medium  $v$  decrease.

18. Given below are two statements :  
 Statement I: In hydrogen atom, the frequency of radiation when an electron jumps from lower energy orbit ( $E_1$ ) to higher energy orbit ( $E_2$ ), is given as  
 $hf = E_2 - E_1$   
 Statement II : The jumping of electron from higher energy orbit ( $E_2$ ) to lower energy orbit ( $E_1$ ) is associated with frequency of radiation given as  $f = (E_2 - E_1) / h$   
 This condition is Bohr's frequency condition.

In the light of the above statements, choose the correct answer from the options given below :

- (A) Both statement I and statement II are true.  
 (B) Both statement I and statement II are false.  
 (C) Statement I is correct but statement II is false.  
 (D) Statement I is incorrect but statement II is true.

Ans. D

19. For a transistor to act a switch, it must be operated in  
 (A) Active region. (B) Saturation state only.  
 (C) Cut-off state only. (D) Saturation and Cut-off state.

Ans. D

20. We don not transmit low frequency signal to long distance because-  
 (a) The size of the antenna should be comparable to signal wavelength which is unreal solution for a signal of longer wavelength.  
 (b) Effective power radiated by a long wavelength baseband signal would be high.  
 (c) We want to avoid mixing up signals transmitted by different transmitter simultaneously.  
 (d) Low frequency signal can be sent to long distances by superimposing with a high frequency wave as well.

Therefore, the most suitable option will be :

- (A) All statements are true (B) (a), (b) and (c) are true only  
 (C) (a), (c) and (d) are true only (D) (b), (c) and (d) are true only

Ans. C

21. A mass of 10 kg is suspended vertically by a rope of length 5 m from the roof. A force of 30 N is applied at the middle point of rope in horizontal direction. The angle made by upper half of the rope with vertical is  $\theta = \tan^{-1}(x \times 10^{-1})$ . The value of x is \_\_\_\_  
 (Given,  $g = 10\text{m/s}^2$ )

Ans. 03.00

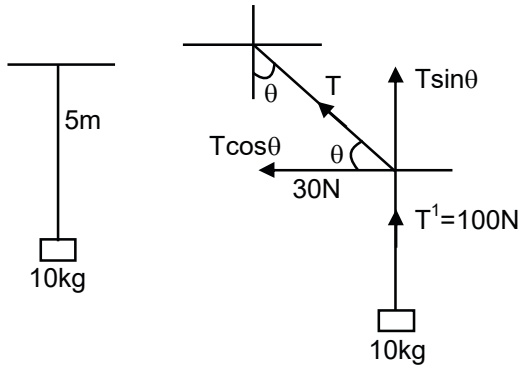

Sol.

$$T \cos \theta = 30 \quad \dots(1)$$

$$T \sin \theta = 100 \quad \dots(2)$$

From equation (1) & (2)

$$\tan \theta = \frac{10}{3}$$

$$\theta = \tan^{-1}\left(\frac{10}{3}\right)$$

22.

A rolling wheel of 12 kg is on an inclined at position P and connected to a mass of 3 kg through a string of fixed length and pulley as shown in figure. Consider PR as friction free surface. The velocity of centre of mass of the wheel when it reaches at the bottom Q of the inclined plane PQ

will be  $\frac{1}{2}\sqrt{xgh}$  m/s. The value of x is \_\_\_\_\_.

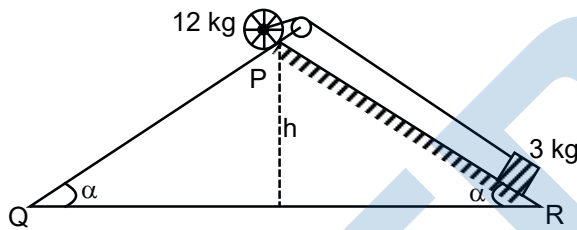

Ans.

**Bonus**

Sol.

Moment of Inertial not mentioned

If  $I = m$

$$12gh - 3gh = \frac{1}{2}3v^2 + \frac{1}{2}12v^2 + \frac{1}{2}\frac{v^2}{r^2}$$

$$9gh = \frac{15v^2}{2} + \frac{1}{2}\frac{v^2}{r^2}$$

$$\text{If } I = mr^2, 9gh = \frac{15}{2}v^2 + \frac{1}{2}12v^2$$

$$\Rightarrow v = \sqrt{\frac{2}{3}gh}$$

23.

A diatomic gas ( $\gamma = 1.4$ ) does 400J of work when it expanded isobarically. The heat given to the gas in the process is \_\_\_\_\_ J.

Ans.

**1400**

Sol.

$$W = 400 \text{ J} = nR\Delta T \text{ (for isobaric process)}$$

$$\Delta Q = ?$$

For isobaric process

$$\Delta Q = nC_p\Delta T$$

$$\Rightarrow \Delta Q = n\left(\frac{\gamma R}{\gamma - 1}\right)\Delta T$$

$$\Rightarrow \Delta Q = nR\Delta T\left(\frac{\gamma}{\gamma - 1}\right)$$

$$\Rightarrow \Delta Q = 400 \times \frac{1.4}{1.4 - 1} = 400 \times \frac{1.4}{.4}$$

$$\Rightarrow \Delta Q = 100 \times 14 = 1400 \text{ J}$$



24. A particle executes simple harmonic motion. Its amplitude is 8 cm and time period is 6 s. The time it will take to travel from its position of maximum displacement to the point corresponding to half its amplitude, is \_\_\_\_\_ s.

Ans. 01.00

Sol. Time taken by the particle from

$$x = +A \cos \omega t + \frac{A}{2} \text{ is } \frac{T}{6}$$

$$\text{So } \frac{T}{6} = \frac{6}{6} = 1 \text{ sec.}$$

25. A parallel plate capacitor is made up of stair like structure with a plate area A of each stair and that is connected with a wire of length b, as shown in the figure. The capacitor of the arrangement is  $\frac{x \epsilon_0 A}{15 b}$ ,

The value of x is \_\_\_\_\_.

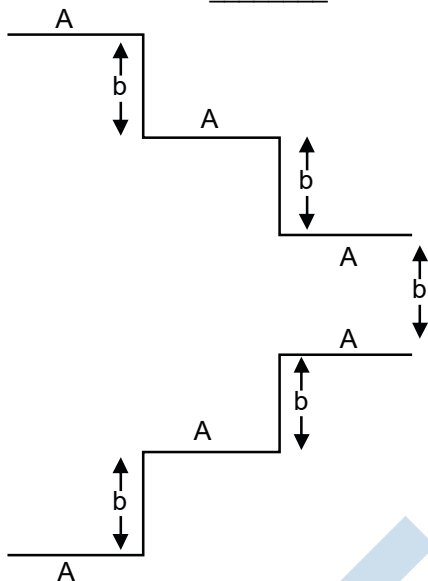

Ans. 23.00

Sol. There will be three Capacitors in parallel combination in given system so Equivalent capacitance  $C = C_1 + C_2 + C_3$

$$\Rightarrow c = \frac{\epsilon_0 A}{5d} + \frac{\epsilon_0 A}{3d} + \frac{\epsilon_0 A}{d} = \frac{\epsilon_0 A}{d} \left( \frac{1}{5} + \frac{1}{3} + 1 \right)$$

$$\Rightarrow \frac{23 \epsilon_0 A}{15 d}$$

26. The current density in a cylindrical wire of radius  $r = 4.0 \text{ mm}$  is  $1.0 \times 10^6 \text{ A/m}^2$ .

The current through the outer portion of the wire between radial distances  $\frac{r}{2}$  and  $r$  is  $x\pi A$ . where x is

Ans. 12.00

Sol. Current =  $J \times \text{Area}$

$$= J \times \pi \left[ R^2 - \left( \frac{R}{2} \right)^2 \right]$$

$$= J\pi \frac{3R^2}{4}$$

$$= 10^6 \times \pi \times 3 \times \left( \frac{4 \times 10^{-3}}{4} \right)^2$$

$$\Rightarrow \pi \times 3 \times \frac{16}{4} = 12\pi \text{ Amp}$$

27. In the given circuit 'a' is an arbitrary constant. The value of m for which the equivalent circuit resistance is minimum, will be  $\sqrt{\frac{x}{2}}$ . The value of x is \_\_\_\_\_.

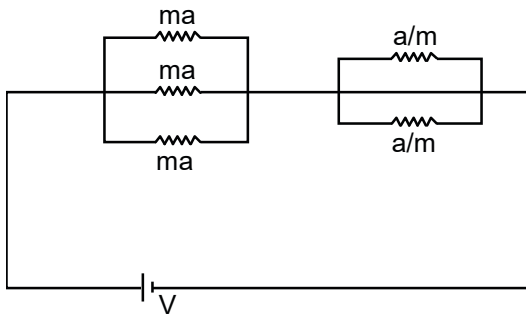

Ans. 03.00

Sol.  $R_{eq} = \frac{ma}{3} + \frac{a}{2m}$

$R_{eq}$  is function of  $m$

$\therefore$  for Minima of  $m$

$$\frac{d_{R_{eq}}}{dm} = 0$$

$$\frac{a}{3} + \frac{a}{2} \left( \frac{-1}{m^2} \right) = 0$$

$$\frac{1}{3} = \frac{1}{2m^2}$$

$$m^2 = \frac{3}{2}$$

$$m = \sqrt{\frac{3}{2}}$$

28. A deuteron and a proton moving with equal kinetic energy enter into to a uniform magnetic field at right angle to the field. If  $r_d$  and  $r_p$  are their circular paths respectively. Then the ratio  $\frac{r_d}{r_p}$  will be  $\sqrt{x}:1$  where  $x$

is \_\_\_\_\_.

Ans. 02.00

Sol. For circular path in magnetic field

$$r = \frac{mV}{qB} = \frac{\sqrt{2mE_k}}{qB}$$

So,

	P	d
m	1	2
q	+e	e

$$r_1 : r_2 = \sqrt{2} : 1$$

29. A metallic rod of length 20 cm is placed in North-south direction and is moved at a constant speed of 20 m/s towards East. The horizontal component of the Earth's magnetic field at that placed is  $4 \times 10^{-3}$  T and the angle of dip is  $45^\circ$ . The emf induced in the rod is \_\_\_\_\_ mV.

Ans. 16.00

Sol. vertical component of earths magnetic field is perpendicular to length of the wire so

Induced emf in wire  $e = B_v \ell v$

angle of dip  $f = 45^\circ$  so  $B_v = B_H$

$$e = B_v \ell v = 4 \times 10^{-3} \times 0.2 \times 20$$

$$= 16 \times 10^{-3} \text{ volt}$$

30. The cut-off voltage of the diodes (shown in figure) in forward bias is 0.6V. The current through the resister of  $40 \Omega$  is \_\_\_\_\_ mA.

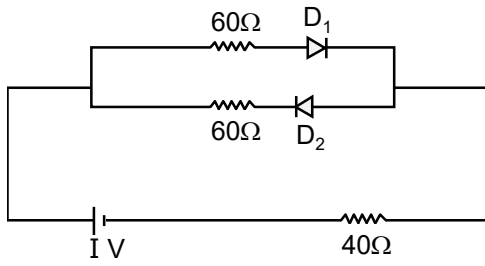

**Ans.** 04.00

**Sol.**  $D_1$  is forward biased  $D_2$  is reverse biased

$$i = \frac{1 - 0.6}{100} = 4\text{mA}$$

MENIIT  
NEET / IIT-JEE / FOUNDATION

PART : CHEMISTRY

1. Which amongst the given plots in the correct plot for (p) vs density (d) for an ideal gas ?

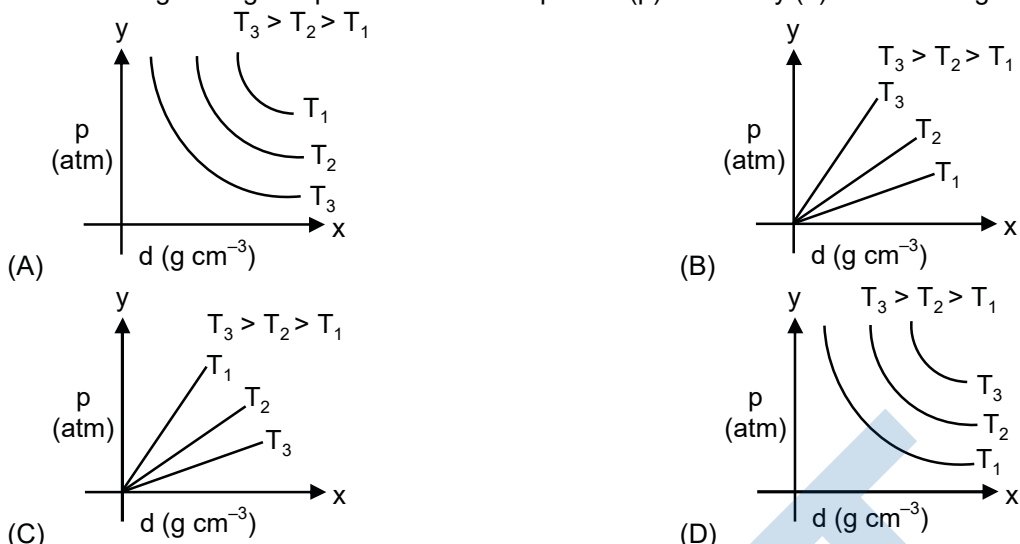

Ans. B  
Sol.

$$PV = nRT$$

$$P = \left[ \frac{w}{v} \right] \frac{RT}{M}$$

$$P = \frac{dRT}{M} \text{ so is } \propto d \quad \text{Slope} = \frac{RT}{M}$$

Greater is slope greater is temperature.

2. Question : Identify the **incorrect** statement for PCl<sub>5</sub> from the following.  
 (A) In this molecule, orbitals of phosphorous are assumed to undergo sp<sup>3</sup> hybridization.  
 (B) The geometry of PCl<sub>5</sub> is trigonal bipyramidal.  
 (C) PCl<sub>5</sub> has two axial bonds stronger than three equatorial bonds.  
 (D) The three equatorial bonds of PCl<sub>5</sub> lie in a plane.

Ans. C  
Sol.

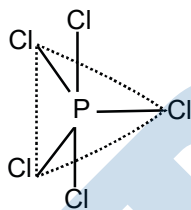

Hybridisation = sp<sup>3</sup>d

3. **Statement I:** Leaching of gold with cyanide ion in absence of air/O<sub>2</sub> leads to cyano complex of Au(III).

**Statement II:** Zinc is oxidized during the displacement reaction carried out for gold extraction.

In the light of the above statement, choose the **correct** answer from the options given below.

- (A) Both statement I and statement II are correct.
- (B) Both statement I and statement II are incorrect.
- (C) Statement I is correct but statement II are incorrect.
- (D) Statement I is incorrect but statement II are correct.

Ans. D

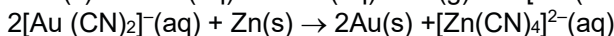
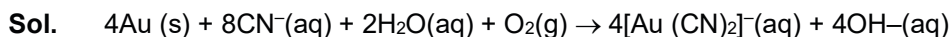

4. The correct order of increasing intermolecular hydrogen bond strength is

- (A) HCN < H<sub>2</sub>O < NH<sub>3</sub>
- (B) HCN < CH<sub>4</sub> < NH<sub>3</sub>
- (C) CH<sub>4</sub> < HCN < NH<sub>3</sub>
- (D) CH<sub>4</sub> < NH<sub>3</sub> < HCN

Ans. C

Sol. Correct order of H-bond strength is :



5. The correct order of increasing ionic radii is

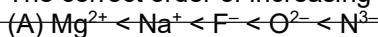

- (B)  $N^{3-} < O^{2-} < F^- < Na^+ < Mg^{2+}$   
 (C)  $F^- < Na^+ < O^{2-} < Mg^{2+} < N^{3-}$   
 (D)  $Na^+ < F^- < Mg^{2+} < O^{2-} < N^{3-}$

Ans. **A**  
 Sol.

Species	$N^{3+}$	$O^{2-}$	$F^-$	$Na^+$	$Mg^{2+}$
No. of $e^-$	10	10	10	10	10
Z	7	8	9	11	12

For isoelectronic species greater is Z smaller is size of ion.

6. The gas produced by treating an aqueous solution of ammonium chloride with sodium nitrite is  
 (A)  $NH_3$  (B)  $N_2$  (C)  $N_2O$  (D)  $Cl_2$

Ans. **B**  
 Sol.

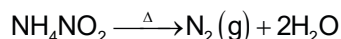
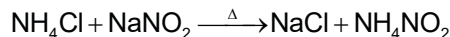

7. Given below are two statements: one is labelled as **Assertion A** and the other is labelled as **Reason R**.  
**Assertion A:** Fluorine forms one oxoacid.

**Reason R:** Fluorine has smallest size amongst all **most appropriate** answer from the options given below.

- (A) Both **A** and **R** are correct **R** is the correct explanation of **A**.  
 (B) Both **A** and **R** are correct **R** is NOT the correct explanation of **A**.  
 (C) **A** is correct but **R** is not correct.  
 (D) **A** is not correct but **R** is correct.

Ans. **A**  
 Sol.

Due to small size & high electronegativity F can act as central atom in higher oxidation state so F forms only one oxy acid HOF.

8. In 3d series, the metal having the highest  $M^{2+}/M$  standard electrode potential is  
 (A) Cr (B) Fe (C) Cu (D) Zn

Ans. **C**  
 Sol.

$$E_{Zn^{2+}|Zn}^{\circ} = -0.76V$$

$$E_{Cr^{2+}|Cr}^{\circ} = -0.91V$$

$$E_{Cu^{2+}|Cu}^{\circ} = 0.34V$$

$$E_{Fe^{2+}|Fe}^{\circ} = -0.44V$$

9. The 'f' orbitals are half and completely filled, respectively in lanthanide ions  
 [Given : Atomic no. Eu, 63; Sm, 69; Tb, 65; Yb, 70; Dy, 66]

- (A)  $Eu^{2+}$  and  $Tm^{2+}$  (B)  $Sm^{2+}$  and  $Tm^{3+}$   
 (C)  $Tb^{4+}$  and  $Yb^{2+}$  (D)  $Dy^{3+}$  and  $Yb^{3+}$

Ans. **C**  
 Sol.

**Ion** **Electronic configuration**

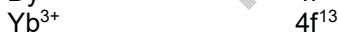
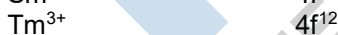

10. Arrange the following coordination compounds in the increasing order of magnetic moments.  
 (Atomic numbers: Mn = 25; Fe = 26)

- (A)  $[FeF_6]^{3-}$  (B)  $[Fe(CN)_6]^{3-}$   
 (C)  $[MnCl_6]^{3-}$  (high spin) (D)  $[Mn(CN)_6]^{3-}$

Choose the correct answer from the options given below :

- (A)  $A < B < D < C$  (B)  $B < D < C < A$   
 (C)  $A < C < D < B$  (D)  $B < D < A < C$

Ans. **B**  
 Sol.

**Complex** **Electronic configuration**





11. On the surface of polar stratospheric clouds, hydrolysis of chlorine nitrate gives A and B while its reaction with HCl produces B and C. A, B and C are, respectively  
 (A) HOCl, HNO<sub>3</sub>, Cl<sub>2</sub> (B) Cl<sub>2</sub>, HNO<sub>3</sub>, HOCl  
 (C) HClO<sub>2</sub>, HNO<sub>2</sub>, HOCl (D) HOCl, HNO<sub>2</sub>, Cl<sub>2</sub>O

Ans. A

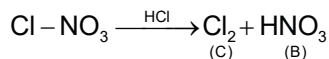
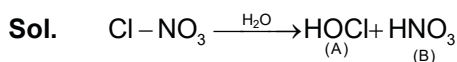

12. Which of the following is most stable?

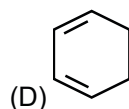
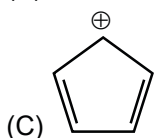
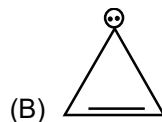
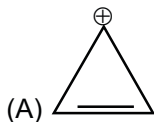

Ans. A

Sol. Due to Aromaticity

13. What will be the major product of following sequence of reactions ?

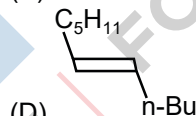
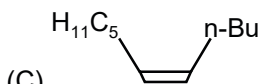
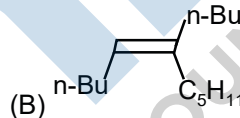
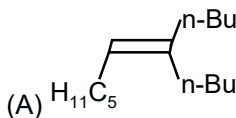
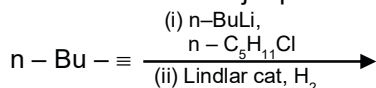

Ans. C



Sol.

14. Product 'A' of following sequence of reaction is

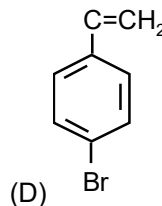
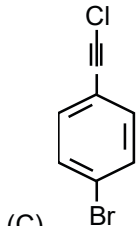
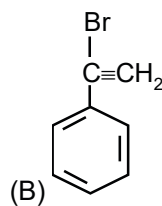
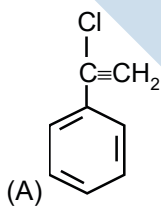
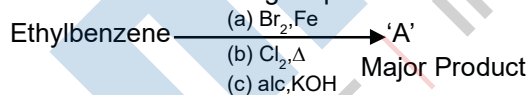

Ans. D

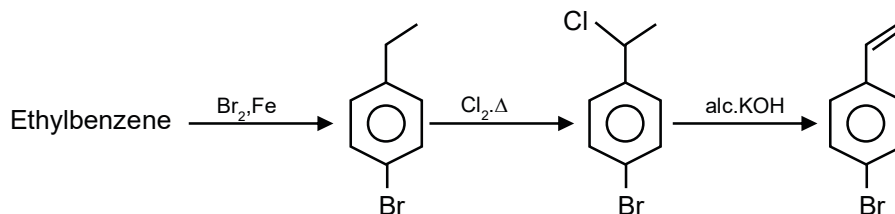

Sol.  
15.

Match **List I** with **List II**.

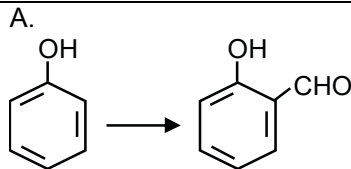
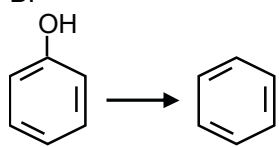
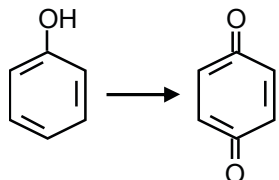
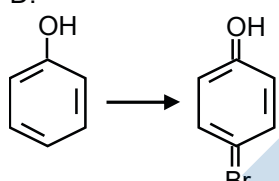
List I	List II
A. 	I. Br <sub>2</sub> in CS <sub>2</sub>
B. 	II. Na <sub>2</sub> Cr <sub>2</sub> O <sub>7</sub> /H <sub>2</sub> SO <sub>4</sub>
C. 	III. Zn
D. 	IV. CHCl <sub>3</sub> /NaOH

Choose the correct answer from the option given below :

(A) A-IV, B-III, C-II, D-I

(B) A-IV, B-III, C-I, D-II

(C) A-II, B-III, C-I, D-IV

(B) A-IV, B-II, C-III, D-I

Ans.

A

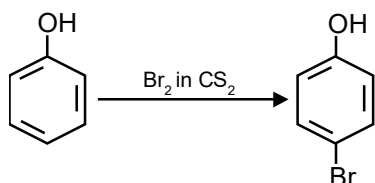
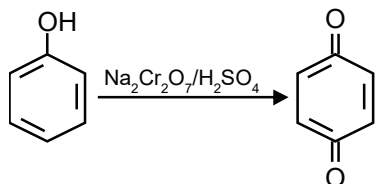
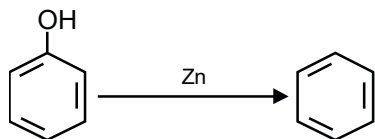
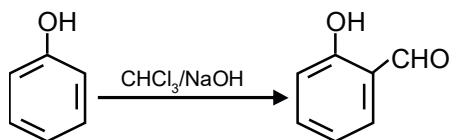

Sol.

16. Decarboxylation of all six possible forms of diaminobenzoic acids  $\text{C}_6\text{H}_3(\text{NH}_2)_2\text{COOH}$  yields three products A, B and C. Three acids give a product 'A' two acids give a product 'B' and one acid give a product 'C'. The melting point of product 'C' is  
 (A)  $60^\circ\text{C}$  (B)  $90^\circ\text{C}$  (C)  $104^\circ\text{C}$  (D)  $142^\circ\text{C}$

Ans. D

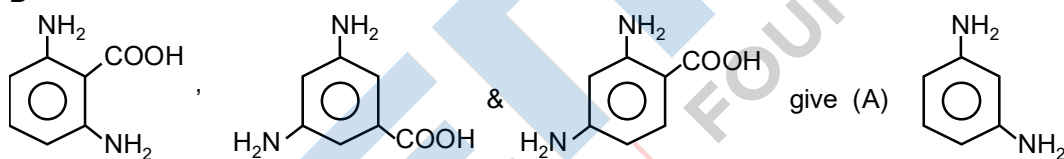

on decarboxylation.

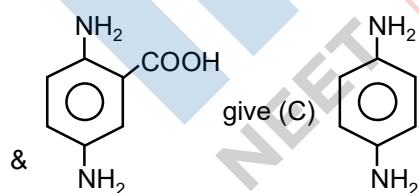
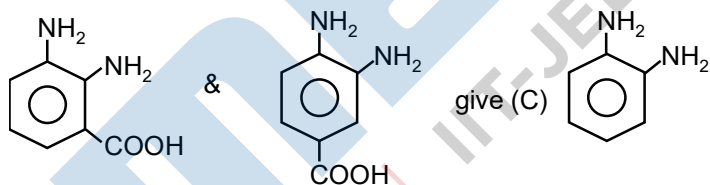

Sol.

17. (C) has highest melting point.  
 Which is true about Buna-H ?  
 (A) It is a linear polymer of 1,3-butadiene.  
 (B) It is obtained by copolymerization of 1,3-butadiene and styrene.  
 (C) It is obtained by copolymerization of 1,3-butadiene and acrylonitrile.  
 (D) The suffix N in Buna-N stands for its natural occurrence.

Ans. C

Sol. Buna-N is obtained by copolymerization of 1,3-butadiene and acrylonitrile.

18.

Given below are two statement.

Statement I: Maltose has two  $\alpha$ -D-glucose units linked at  $\text{C}_1$  and  $\text{C}_4$  and is a reducing sugar.

Statement II: Maltose has two monosaccharides:  $\alpha$ -D-glucose and  $\beta$ -D-glucose linked at  $\text{C}_1$  and  $\text{C}_6$  and it is a non-reducing sugar.

In the light of the statements, choose the correct answer form the options given belo.

(A) Both Statement I and Statement II are true.

Corporate Office: 44-A/1, Kalu Sarai, New Delhi 110016 | Web: www.meniit.com



- (B) Both Statement I and Statement II are false.  
 (C) Statement I is true but Statement II are false.  
 (D) Statement I is false but Statement II is true.

Ans. C

Sol. Maltose has two  $\alpha$ -D glucose unit linked at C<sub>1</sub> and C<sub>4</sub> and maltose is a reducing sugar due to Hemi-acetal group.

19. Match List I with List II.

List I	List II
A. Antipyretic	I. Reduces pain
B. Analgesic	II. Reduces stress
C. Tranquilizer	III. Reduces fever
D. Antacid	IV. Reduces acidity (stomach)

Choose the correct answer from the

- (A) A-III, B-I, C-II, D-IV  
 (B) A-III, B-I, C-IV, D-II  
 (C) A-I, B- IV, C-II, D-I  
 (D) A-I, B-III, C- II, D-IV

Ans. A

Sol. It is fact

20. Match List I with List II.

List I (Anion)	List II (gas evolved on reaction with dil.H <sub>2</sub> SO <sub>4</sub> )
A. CO <sub>3</sub> <sup>2-</sup>	I. Colour gas which turns lead acetate paper black.
B. S <sup>2-</sup>	II. Colourless gas which turns acidified potassium dichromate solution green.
C. SO <sub>3</sub> <sup>2-</sup>	III. Brown fumes which turns acidified KI solution containing starch blue.
D. NO <sub>2</sub> <sup>-</sup>	IV. Colourless gas evolved with brisk effervescence, which turns lime water milky.

Choose the correct answer form the option given below :

- (A) A-III, B-I, C-II, D-IV  
 (B) A-II, B-I, C-IV, D-III  
 (C) A-IV, B- I, C-III, D-II  
 (D) A-IV, B-I, C-II, D-III

Ans. D

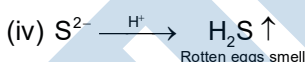
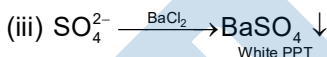
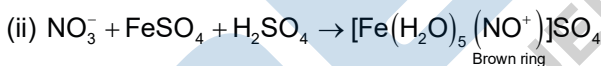
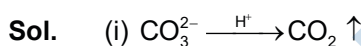

21. 116g of a substance upon dissociation reaction, yields 7.5g of hydrogen, 60g of oxygen and 48.5g of carbon. Given that the atomic masses of H, O and C are 1, 16 and 12, respectively. The data agree with how many formulae of the following ? \_\_\_\_\_.

- (A) CH<sub>3</sub>COOH (B) HCHO (C) CH<sub>3</sub>OOCH<sub>3</sub> (D) CH<sub>3</sub>CHO

Ans. 2

Sol. (Organic Compound containing C, H, O)  $\xrightarrow{\text{dissociation}} \text{H} + \text{O} + \text{C}$   
7.5 gram    60 gram    48.5 gram % of H in organic compound

$$= \frac{7.5}{116} \times 100 = 6.465\%$$

(A) % of H =  $\frac{4}{60} \times 100 = 6.6$

(B) % of H =  $\frac{2}{30} \times 100 = 6.6$

(C) % of H =  $\frac{6}{62} \times 100 = 7.677$

(D) % of H =  $\frac{4}{44} \times 100 = 9.09$

22. Consider the following set of quantum numbers.

	n	l	m <sub>l</sub>
A.	3	3	-3
B.	3	2	-2
C.	2	1	+1
D.	2	2	+2

The number of correct sets of quantum numbers is \_\_\_\_\_.

Corporate Office: 44-A/1, Kalu Sarai, New Delhi 110016 | Web: www.meniit.com

**Ans. 2****Sol.** For possible set of quantum number. $n > \ell, m = -\ell \text{ to } +\ell$  (including zero).**23.** BeO reacts with HF in presence of ammonia to give [A] which on thermal decomposition produces [B] and ammonium fluoride. Oxidation state of Be in [A] is \_\_\_\_\_**Ans. 2****Sol.**  $\text{BeO} + \text{NH}_3 \rightarrow \text{Be}_3\text{N}_2 + \text{H}_2\text{O}$ 

(A)

 $\text{Be}_3\text{N}_2 + \text{HF} \rightarrow \text{BeF}_2 + \text{NH}_4\text{F}$ 

(B)

Oxidation state of Be is +2

**24.** When 5 moles of He gas expand isothermally and reversibly at 300 K from 10 litre to 20 litre, the magnitude of the maximum work obtained is \_\_\_\_\_ J. [nearest integer] (Given :  $R = 8.3 \text{ JK}^{-1} \text{ mol}^{-1}$  and  $\log 2 = 0.3010$ )**Ans. 8630****Sol.** For isothermal reversible process

$$W = -2.303nRT \log\left(\frac{V_2}{V_1}\right)$$

$$= -2.303 \times 5 \times 8.3 \times 300 \log\left(\frac{20}{10}\right)$$

$$= -8630.37 \text{ J}$$

**25.** A solution containing  $2.5 \times 10^{-3} \text{ kg}$  of a solute dissolved in  $75 \times 10^{-3} \text{ kg}$  of water boils at 373.535 K, The molar mass of the solute is \_\_\_\_\_  $\text{g mol}^{-1}$  [nearest integer] (Given :  $K_b(\text{H}_2\text{O}) = 0.52 \text{ K kg mol}^{-1}$  and boiling point of water = 373.15K)**Ans. 45****Sol.** Boiling point of solution ( $T_b$ ) = 373.535 KBoiling point of solvent ( $T_b^\circ$ ) = 373.15 K

$$\Delta T_b = (T_b - T_b^\circ) = 373.535 - 373.15 = 0.385$$

$$\Delta T_b = 0.385$$

$$\Delta T_b = (K_b)m$$

$$0.385 = 0.52 \left[ \frac{2.5 \times 1000}{M_{\text{solute}} \times 75} \right]$$

$$M_{\text{solute}} = 45.02 \text{ g/mol}$$

**26.** pH value of 0.001 M NaOH solution is \_\_\_\_\_.**Ans. 11****Sol.**  $\text{NaOH} \rightarrow \text{Na}^+ + \text{OH}^-$ 

$$10^{-3} \text{M} \quad 10^{-3} \text{M} \quad 10^{-3} \text{M}$$

$$[\text{OH}^-] = 10^{-3} \quad \text{pOH} = 3$$

$$\text{pH} = 11$$

**27.** For the reaction taking place in the cell :

$$E^\circ_{\text{cell}} = +0.5332 \text{ V.}$$

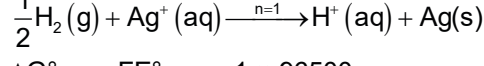
The value of  $\Delta_f G^\circ$  is \_\_\_\_\_  $\text{kJ mol}^{-1}$ . (in nearest integer)**Ans. 51****Sol.** Anode  $\Rightarrow \frac{1}{2} \text{H}_2(\text{g}) \rightarrow \text{H}^+(\text{aq}) + \text{e}^-$ Cathode  $\Rightarrow \text{Ag}^+ + \text{e}^- \rightarrow \text{Ag(s)}$ 

$$\Delta G^\circ = -nFE^\circ_{\text{cell}} = -1 \times 96500$$

**28.** It has been found that for a chemical reaction with rise in temperature by 9 K the rate constant gets double. Assuming a reaction to be occurring at 300K, the value of activation energy is found to be \_\_\_\_\_  $\text{kJ mol}^{-1}$ . [nearest integer] (Given  $\ln 10 = 2.3, R = 8.3 \text{ J K}^{-1} \text{ mol}^{-1}, \log 2 = 0.30$ )**Ans. 59****Sol.** Rise in temperature 9K

Initial temperature = 300 K

$$\log\left(\frac{K_{309}}{K_{300}}\right) = \frac{E_a}{2.3R} \left[ \frac{1}{300} - \frac{1}{309} \right]$$

$$\log 2 = \frac{E_a}{2.3R} \left[ \frac{9}{300 \times 309} \right]$$

$$E_a = \frac{2.3 \times 0.30 \times 300 \times 309}{9}$$

$$E_a = 58.988 \times 10^3 \text{ J} = 58.988 \text{ kJ} = 59 \text{ kJ}$$

29.

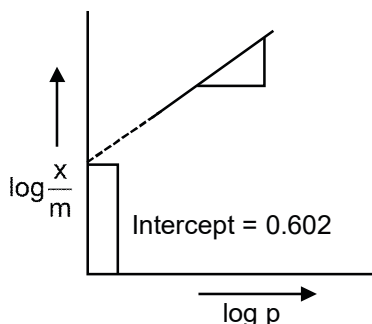

If the initial pressure of a gas is 0.03 atm, the mass of the gas adsorbed per gram of the adsorbent is  $\underline{\hspace{2cm}} \times 10^{-2} \text{g}$ .

Ans. **12**

Sol.  $\left(\frac{x}{m}\right) = KP^{1/n}$

$$\log\left(\frac{x}{m}\right) = \log K + \frac{1}{n} \log P$$

Intersect  $\log K = 0.602 = \log 4$

$K = 4$

Slope  $\Rightarrow \frac{1}{n} = 1$  so  $n = 1$

so  $\left(\frac{x}{m}\right) = 4(0.03) = 0.12 = 12 \times 10^{-2}$

30. 0.25g of an organic compound containing chloride gave 0.40 g of silver chloride in Carius estimation. The percentage of chlorine present in the compound is  $\underline{\hspace{2cm}}$ . (in nearest integer)

Ans. **40**

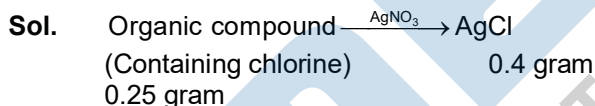

Mole of AgCl =  $\left(\frac{0.4}{143.5}\right)$

$W_{\text{Cl}} = \left(\frac{0.4}{143.5}\right) \times 35.5$

% of Cl =  $\left[\frac{0.4}{143.5} \times 35.5\right] \times \frac{100}{0.25} = 39.58 \approx 40$

**PART : MATHEMATICS  
SECTION-A**

1. The number of point of intersection of  $|z - (4 + 3i)| = 2$  and  $|z| + |z - 4| = 6$ ,  $z \in \mathbb{C}$  is :  
 (A) 0 (B) 1 (C) 2 (D) 3

**Ans. C**

**Sol.** C :  $(x - 4)^2 + (y - 3)^2 = 4$

E :  $\frac{(x - 2)^2}{9} + \frac{y^2}{5} = 1$

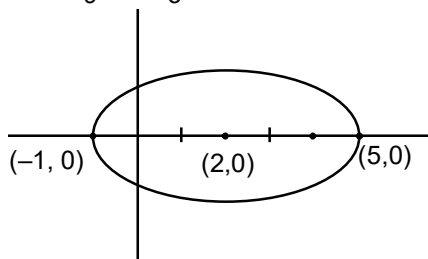

Lower Extremity of vertical diameter of circle  $\rightarrow (4, 1)$

Put in ellipse  $\Rightarrow \frac{(4 - 2)^2}{9} + \frac{1}{5} - 1$

$= \frac{4}{9} + \frac{1}{5} - 1$

$= \frac{29}{45} - 1 < 0$

Two Solutions

Answer (C)

2. Let  $f(x) = \begin{vmatrix} a & -1 & 0 \\ ax & a & -1 \\ ax^2 & ax & a \end{vmatrix}$ ,  $a \in \mathbb{R}$ . Then the sum of which the squares of all the values of a for  $2f(10) -$

$f'(5) + 100 = 0$  is :

- (A) 117 (B) 106 (C) 125 (D) 136

**Ans. C**

**Sol.**  $f(x) = \begin{vmatrix} a & -1 & 0 \\ ax & a & -1 \\ ax^2 & ax & a \end{vmatrix}$

$f(x) = a \begin{vmatrix} 1 & -1 & 0 \\ x & a & -1 \\ x^2 & ax & a \end{vmatrix}$

$= a [1 (a^2 + ax) + 1 (ax + x^2)]$

$\Rightarrow f(x) = a (x + a)^2$

So,  $f'(x) = 2a (x + a)$

as,  $2f(10) - f'(5) + 100 = 0$

$\Rightarrow 2 \times 2a (10 + a) - 2a (5 + a) + 100 = 0$

$\Rightarrow 40a + 4a^2 - 10a - 2a^2 + 100 = 0$

$2a^2 + 30a + 100 = 0$

$\Rightarrow a^2 + 15a + 50 = 0$

$(a + 10)(a + 5) = 0$

$a = -10$  or  $a = -5$

Required  $= (-10)^2 + (-5)^2 = 125$

3. Let for some real numbers  $\alpha$  and  $\beta$ ,  $a = \alpha - i\beta$ . If the system of equation  $4ix + (1 + i)y = 0$  and  $8\left(\cos\frac{2\pi}{3} + i\sin\frac{2\pi}{3}\right)x + a\bar{y} = 0$  has more than one solution then  $\frac{\alpha}{\beta}$  is equal to :

- (A)  $-2 + \sqrt{3}$                       (B)  $2 - \sqrt{3}$                       (C)  $2 + \sqrt{3}$                       (D)  $-2 - \sqrt{3}$

Ans. **B**

Sol.  $a = \alpha - i\beta$  ;  $\alpha \in \mathbb{R}$  ;  $\beta \in \mathbb{R}$   
 $4ix + (1 + i)y = 0$  and

$$8\left(\cos\frac{2\pi}{3} + i\sin\frac{2\pi}{3}\right)x + a\bar{y} = 0$$

$$\begin{vmatrix} 4i & 1+i \\ 8e^{i2\pi/3} & a \end{vmatrix} = 0$$

$$\Rightarrow 4i\bar{a} - (1+i)8e^{i2\pi/3} = 0$$

$$\Rightarrow 4i(\alpha + i\beta) - 8(1+i)\left(\frac{-1+i\sqrt{3}}{2}\right) = 0$$

$$\Rightarrow i\alpha - \beta + 1 + \sqrt{3} + i(1 - \sqrt{3}) = 0$$

$$\Rightarrow \beta = \sqrt{3} + 1$$

$$\alpha = \sqrt{3} - 1$$

$$\text{So, } \frac{\alpha}{\beta} = \frac{\sqrt{3} - 1}{\sqrt{3} + 1} = 2 - \sqrt{3}$$

4. Let A and B be two  $3 \times 3$  matrices such that  $AB = I$  and  $|A| = \frac{1}{8}$  then  $|\text{adj}(\text{B adj}(2A))|$  is equal to

- (A) 16                      (B) 32                      (C) 64                      (D) 128

Ans. **C**

Sol.

$$AB = I$$

$$|\text{adj}(B \text{ adj}(2A))| = |B \text{ adj}(2A)|^2$$

$$= |B|^2 |\text{adj}(2A)|^2$$

$$= |B|^2 (|2A|)^2 = |B|^2 (2^6 |A|)^2$$

$$|A| = \frac{1}{8} \text{ and } |AB| = 1 \Rightarrow |A| |B| = 1$$

$$\Rightarrow \frac{1}{8} |B| = 1$$

$$\Rightarrow |B| = 8$$

$$\text{Required value} = 64$$

5. Let  $S = 2 + \frac{6}{7} + \frac{12}{7^2} + \frac{20}{7^3} + \frac{30}{7^4} + \dots$  then  $4S$  is equal to

- (A)  $\left(\frac{7}{3}\right)^2$                       (B)  $\frac{7^3}{3^2}$                       (C)  $\left(\frac{7}{3}\right)^3$                       (D)  $\frac{7^2}{7^3}$

Ans. **C**

Sol.

$$S = 2 + \frac{6}{7} + \frac{12}{7^2} + \frac{20}{7^3} + \frac{30}{7^4} + \dots$$

Considering infinite sequence,

$$S = 2 + \frac{6}{7} + \frac{12}{7^2} + \frac{20}{7^3} + \frac{30}{7^4} + \dots$$

$$\frac{S}{7} = \frac{2}{7} + \frac{6}{7^2} + \frac{12}{7^3} + \frac{20}{7^4} + \dots$$

$$\Rightarrow \frac{6S}{7} = 2 + \frac{4}{7} + \frac{6}{7^2} + \frac{8}{7^3} + \frac{10}{7^4} + \dots$$

$$\Rightarrow \frac{6S}{7^2} = \frac{2}{7} + \frac{4}{7^2} + \frac{6}{7^3} + \frac{8}{7^4} + \dots$$

$$\frac{6S}{7} \left(1 - \frac{1}{7}\right) = 2 + \frac{2}{7} + \frac{2}{7^2} + \frac{2}{7^3} + \dots$$

$$\Rightarrow \frac{6^2 S}{7^2} = \frac{2}{1 - \frac{1}{7}} = \frac{2}{6} \times 7$$

$$\Rightarrow S = \frac{2 \times 7^3}{6^3} \Rightarrow 4S = \frac{7^3}{3^3} = \left(\frac{7}{3}\right)^3$$

6. If  $a_1, a_2, a_3, \dots$  and  $b_1, b_2, b_3, \dots$  are A.P. and  $a_1 = 2, a_{10} = 3, a_1 b_1 = 1 = a_{10} b_{10}$  then  $a_4 b_4$  is equal to

(A)  $\frac{35}{27}$

(B) 1

(C)  $\frac{27}{28}$

(D)  $\frac{28}{27}$

Ans. D

Sol.  $a_1, a_2, a_3, \dots$  A.P.;  $a_1 = 2; a_{10} = 3; d_1 = \frac{1}{9}$

$$b_1, b_2, b_3, \dots$$
 A.P.;  $b_1 = \frac{1}{2}; b_{10} = \frac{1}{3}; d_2 = \frac{-1}{54}$

[Using  $a_1 b_1 = 1 = a_{10} b_{10}$ ;  $d_1$  &  $d_2$  are common difference respectively]

$$a_4 \cdot b_4 = (2a + 3d_1) \left(\frac{1}{2} + 3d_2\right)$$

$$= \left(2 + \frac{1}{3}\right) \left(\frac{1}{2} - \frac{1}{18}\right)$$

$$= \left(\frac{7}{3}\right) \left(\frac{8}{18}\right) = \frac{28}{27}$$

7. If  $m$  and  $n$  respectively are the number of local maximum and local minimum points of the

function  $f(x) = \int_0^{x^2} \frac{t^2 - 5t + 4}{2 + e^t} dt$ , then the ordered pair  $(m, n)$  is equal to

(A) (3, 2)

(B) (2, 3)

(C) (2, 2)

(D) (3, 4)

Ans. B

Sol.  $m = L \cdot \max$

$N = L \cdot \min$

$$f(x) = \int_0^{x^2} \frac{t^2 - 5t + 4}{2 + e^t} dt$$

$$f'(x) = \frac{(x^4 - 5x^2 + 4)2x}{2 + e^{x^2}} = \frac{2x(x^2 - 1)(x^2 - 4)}{2 + e^{x^2}}$$

$$= \frac{2x(x-1)(x+1)(x-2)(x+2)}{2 + e^{x^2}}$$

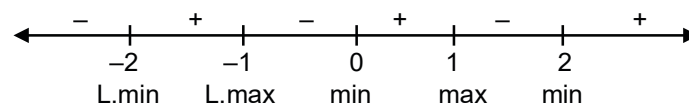

So,  $m = 2$  and  $n = 3$

8. Let  $f$  be a differentiable function in  $\left(0, \frac{\pi}{2}\right)$ . If  $\int_{\cos x}^1 t^2 f(t) dt = \sin^3 x + \cos x$  then  $\frac{1}{\sqrt{3}} f'\left(\frac{1}{\sqrt{3}}\right)$  is equal to :
- (A)  $6 - 9\sqrt{2}$                       (B)  $6 - \frac{9}{\sqrt{2}}$                       (C)  $\frac{9}{2} - 6\sqrt{2}$                       (D)  $\frac{9}{\sqrt{2}} - 6$

**Ans. B**

**Sol.** At right hand vicinity of  $x = 0$  given equation does not satisfy

$\therefore$  LHS =  $\int_{\cos x}^1 t^2 f(t) dt = 0$ , RHS =  $\lim_{x \rightarrow 0^+} (\sin^3 x + \cos x) = 1$  LHS  $\neq$  RHS hence data given in questions is wrong hence BONUS

Correct data should have been  $\int_{\cos x}^1 t^2 f(t) dt = \sin^3 x + \cos x - 1$

**Calculation for option**

Differentiating both sides

$$-\cos^2 x f'(\cos x) \cdot (-\sin x) = 3\sin^2 x \cdot \cos x - \sin x$$

$$\Rightarrow f(\cos x) = 3 \tan x - \sec^2 x$$

$$\Rightarrow f(\cos x)(-\sin x) = 3\sec^2 x - 2\sec^2 x \tan x$$

$$\Rightarrow f'(\cos x) \cos x = \frac{2}{\cos^2 x} - \frac{3}{\sin x \cdot \cos x}$$

$$\text{When } \cos x = \frac{1}{\sqrt{3}}; \sin x = \frac{\sqrt{2}}{\sqrt{3}}$$

$$\therefore f'\left(\frac{1}{\sqrt{3}}\right) \frac{1}{\sqrt{3}} = 6 - \frac{9}{\sqrt{2}}$$

9. The integral  $\int_0^1 \frac{1}{7^{\lfloor x \rfloor}} dx$ , where  $\lfloor \cdot \rfloor$  denotes the greatest integer function is equal to

- (A)  $1 + 6 \log_e \left(\frac{6}{7}\right)$                       (B)  $1 - 6 \log_e \left(\frac{6}{7}\right)$                       (C)  $\log_e \left(\frac{7}{6}\right)$                       (D)  $1 - 7 \log_e \left(\frac{6}{7}\right)$

**Ans. A**

**Sol.**

$$\int_0^1 \frac{1}{7^{\lfloor x \rfloor}} dx = - \int_1^0 \frac{1}{7^{\lfloor x \rfloor}} dx$$

$$= (-1) \left[ \int_1^{1/2} \frac{1}{7} dx + \int_{1/2}^{1/3} \frac{1}{7^2} dx + \int_{1/3}^{1/4} \frac{1}{7^3} dx + \dots \dots \dots \right]$$

$$= \left( \frac{1}{7} + \frac{1}{2 \cdot 7^2} + \frac{1}{3 \cdot 7^3} + \dots \dots \dots \right) - \left( \frac{1}{7 \cdot 2} + \frac{1}{7^2 \cdot 3} + \frac{1}{7^3 \cdot 4} + \dots \dots \dots \right)$$

$$= -\ln \left( 1 - \frac{1}{7} \right) - 7 \left( \frac{1}{7^2 \cdot 2} + \frac{1}{7^3 \cdot 3} + \frac{1}{7^4 \cdot 4} + \dots \dots \dots \right)$$

$$\left[ \text{as } \ln(1+x) = x - \frac{x^2}{2} + \frac{x^3}{3} - \frac{x^4}{4} \dots \dots \dots \right]$$

$$\left[ \text{as } \ln(1-x) = - \left( x + \frac{x^2}{2} + \frac{x^3}{3} + \frac{x^4}{4} \dots \dots \dots \right) \right]$$

$$= -\ln \frac{6}{7} - 7 \left( -\ln \left( 1 - \frac{1}{7} \right) - \frac{1}{7} \right)$$

$$= 6 \ln \frac{6}{7} + 1$$

10. If the solution curve of the differentiable equation  $((\tan^{-1}y)-x)dy = (1 + y^2)dx$  passes through the point  $(1, 0)$  then the abscissa of the point on the curve whose ordinate is  $\tan^{-1}(1)$  is :

- (A)  $2e$  (B)  $\frac{2}{e}$  (C)  $2$  (D)  $\frac{1}{e}$

Ans. B

Sol.  $\frac{dx}{dy} + \frac{x}{1+y^2} = \frac{\tan^{-1}y}{1+y^2}$

I.f =  $e^{\int \frac{1}{1+y^2} dy} = e^{\tan^{-1}y}$

$x e^{\tan^{-1}y} = \int \frac{\tan^{-1}y}{1+y^2} e^{\tan^{-1}y} dy$

$x \cdot e^{\tan^{-1}y} = (\tan^{-1}y - 1) e^{\tan^{-1}y} + c$

$\therefore (1, 0)$  lies on it  $c = 2$ .

For  $y = \tan^{-1}1 \Rightarrow x = \frac{2}{e}$

11. If the equation of the parabola, whose vertex is at  $(5, 4)$  and the directrix is  $3x + y - 29 = 0$ , is  $x^2 + ay^2 + bx + cx + dy + k = 0$  then  $a + b + c + d + k$  is equal to

- (A) 575 (B) -575 (C) 576 (D) -576

Ans. D

Sol. Vertex  $(5, 4)$

Directrix :  $3x + y - 29 = 0$

Co-ordinates of B (foot of directrix)

$\frac{x-5}{3} = \frac{y-4}{1} = -\left(\frac{15+4-29}{10}\right) = 1$

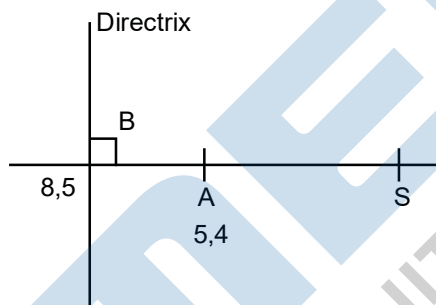

$x = 8, y = 5$

$S = (2, 3)$  (focus)

Equation of parabola

$PS = PM$

So equation is

$x^2 + 9y^2 - 6xy + 134x - 2y - 711 = 0$

$a + b + c + d + k = 9 - 6 + 134 - 2 - 711 = -576$

12. The set of values of  $k$  for which the circle

$C : 4x^2 + 4y^2 - 12x + 8y + k = 0$  lies inside the fourth quadrant and the point  $\left(1, -\frac{1}{3}\right)$  lies on or inside the circle  $C$  is :

- (A) An empty set (B)  $\left[6, \frac{95}{9}\right]$  (C)  $\left[\frac{80}{9}, 10\right]$  (D)  $\left[9, \frac{92}{9}\right]$

Ans. D

Sol.  $C : 4x^2 + 4y^2 - 12x + 8y + k = 0$



$$\Rightarrow x^2 + y^2 - 3x + 2y + \left(\frac{k}{4}\right) = 0$$

$$\text{Centre} \left(\frac{3}{2}, -1\right); r = \sqrt{\frac{13-k}{2}} \Rightarrow k \leq 13 \dots (1)$$

(i) Point  $\left(1, \frac{-1}{3}\right)$  lies on or inside circle C

$$\Rightarrow S_1 \leq 0 \Rightarrow k \leq \frac{92}{9} \dots (2)$$

(ii) C lies in 4<sup>th</sup> quadrant

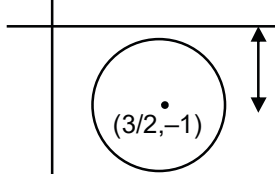

$$r < 1$$

$$\Rightarrow \frac{\sqrt{13-k}}{2} < 1$$

$$\Rightarrow k < 9 \dots (3)$$

$$\text{Hence } (1) \cap (2) \cap (3) \Rightarrow k \in \left(9, \frac{92}{9}\right]$$

13. Let the foot of the perpendicular from the point (1, 2, 4) on the line  $\frac{x+2}{4} = \frac{y-1}{2} = \frac{z+1}{3}$  be P. Then the distance of P from the plane  $3x + 4y + 12z + 23 = 0$
- (A) 5                      (B)  $\frac{50}{13}$                       (C) 4                      (D)  $\frac{63}{13}$

Ans. A  
Sol.

$$P(4\lambda - 2, 2\lambda + 1, 3\lambda + 1) \quad \text{and} \quad (4, 2, 3)$$

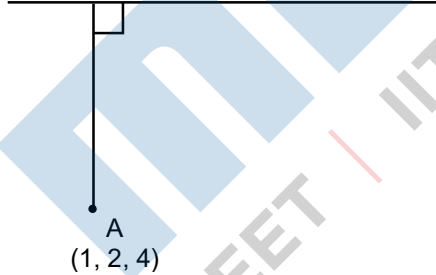

$$\frac{x+2}{4} = \frac{y-1}{2} = \frac{z+1}{3} = \lambda$$

$$(x, y, z) = (4\lambda - 2, 2\lambda + 1, 3\lambda - 1)$$

$$\vec{AP} = (4\lambda - 3)\hat{i} + (2\lambda - 1)\hat{j} + (3\lambda - 5)\hat{k}$$

$$\vec{b} = 4\hat{i} + 2\hat{j} + 3\hat{k}$$

$$\vec{AP} \cdot \vec{b} = 0$$

$$4(4\lambda - 3) + 2(2\lambda - 1) + 3(3\lambda - 5) = 0$$

$$29\lambda = 12 + 2 + 15 = 29$$

$$\lambda = 1$$

$$P = (2, 3, 2)$$

$$3x + 4y + 12z + 23 = 0$$

$$d = \frac{|6 + 12 + 24 + 23|}{\sqrt{9 + 16 + 144}}$$

$$d = \frac{|65|}{13} = 5$$

14. The shortest distance between the lines  $\frac{x-3}{2} = \frac{y-3}{3} = \frac{z-1}{-1}$  and  $\frac{x+3}{2} = \frac{y-6}{1} = \frac{z-5}{3}$  is :
- (A)  $\frac{18}{\sqrt{5}}$                       (B)  $\frac{22}{3\sqrt{5}}$                       (C)  $\frac{46}{3\sqrt{5}}$                       (D)  $6\sqrt{3}$

Ans. A

Sol.  $\frac{x-3}{2} = \frac{y-2}{3} = \frac{z-1}{-1}$   
 $\frac{x+3}{2} = \frac{y-6}{1} = \frac{z-5}{3}$

$A = (3, 2, 1)$                        $B = (-3, 6, 5)$   
 $\vec{n}_1 = 2\hat{i} + 3\hat{j} - \hat{k}$   
 $\vec{n}_2 = 2\hat{i} + \hat{j} - 3\hat{k}$   
 $\vec{BA} = 6\hat{i} - 4\hat{j} - 4\hat{k}$

SHORTEST DISTANCE  $\frac{[\vec{BA} \vec{n}_1 \vec{n}_2]}{|\vec{n}_1 \times \vec{n}_2|}$

$$\vec{n}_1 \times \vec{n}_2 = \begin{vmatrix} \hat{i} & \hat{j} & \hat{k} \\ 2 & 3 & -1 \\ 2 & 1 & 3 \end{vmatrix}$$

$$= 10\hat{i} - 8\hat{j} - 4\hat{k}$$

$$[\vec{BA} \vec{n}_1 \vec{n}_2] = 60 + 32 + 16 = 108$$

$$|\vec{n}_1 \times \vec{n}_2| = \sqrt{100 + 64 + 16} = \sqrt{180}$$

$$S.D. = \frac{108}{\sqrt{180}} = \frac{108}{6\sqrt{5}} = \frac{18}{5}$$

15. Let  $\vec{a}$  and  $\vec{b}$  be the vectors along the diagonal of a parallelogram having area  $2\sqrt{2}$ . Let the angle between  $\vec{a}$  and  $\vec{b}$  be acute.  $|\vec{a}| = 1$  and  $|\vec{a} \cdot \vec{b}| = |\vec{a} \times \vec{b}|$ . If  $\vec{c} = 2\sqrt{2}(\vec{a} \times \vec{b}) - 2\vec{b}$ , then an angle between  $\vec{b}$  and  $\vec{c}$  is :

- (A)  $\frac{\pi}{4}$                       (B)  $-\frac{\pi}{4}$                       (C)  $\frac{5\pi}{6}$                       (D)  $\frac{3\pi}{4}$

Ans. D

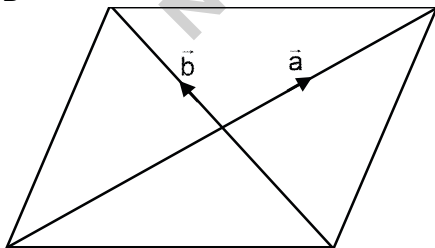

Sol.

$$\text{Area} = \frac{1}{2} |\vec{a} \times \vec{b}| = 2\sqrt{2} \Rightarrow |\vec{a} \times \vec{b}| = 4\sqrt{2}$$

$$|\vec{a}| = 1 \text{ and } |\vec{a} \cdot \vec{b}| = |\vec{a} \times \vec{b}|$$

$$\Rightarrow \cos \theta = \sin \theta$$

$$\Rightarrow \theta = \frac{\pi}{4}$$

$$\therefore |\vec{a} \times \vec{b}| = 4\sqrt{2} \Rightarrow |\vec{a}||\vec{b}|\sin \frac{\pi}{4} = 4\sqrt{2}$$

$$\Rightarrow |\vec{b}| = 8$$

Now,  $\vec{c} = 2\sqrt{2}(\vec{a} \times \vec{b}) - 2\vec{b}$

$$|\vec{c}| = \sqrt{(2\sqrt{2})^2 |\vec{a} \times \vec{b}|^2 + (2|\vec{b}|)^2} = 16\sqrt{2}$$

Now,  $\vec{b} \cdot \vec{c} = -2|\vec{b}|^2$

$$\Rightarrow 8 \times 16\sqrt{2} \times \cos \alpha = -2.64$$

$$\Rightarrow \cos \alpha = \frac{1}{\sqrt{2}} \Rightarrow \alpha = \frac{3\pi}{4}$$

16. The mean and variance of the data 4, 5, 6, 6, 7, 8, x, y where  $x < y$  are 6, and  $\frac{9}{4}$  respectively.

Then  $x^4 + y^2$  is equal to

- (A) 162 (B) 320 (C) 674 (D) 420

Ans. B

Sol.  $\text{mean } \bar{x} = \frac{4+5+6+6+7+8+x+y}{8} = 6$

$$\Rightarrow x + y = 48 - 36 = 12$$

Variance

$$= \frac{1}{8}(16 + 25 + 36 + 36 + 49 + 64 + x^2 + y^2) - 36 = \frac{9}{4}$$

$$\Rightarrow x^2 + y^2 = 80$$

$$\therefore x = 4 ; y = 8$$

$$x^4 + y^2 = 256 + 64 = 320$$

17. If a point A(x, y) lies in the region bounded by the y-axis, straight lines  $2y + x = 6$  and  $5x - 6y = 30$ , then the probability that  $y < 1$  is :

- (A)  $\frac{1}{6}$  (B)  $\frac{5}{6}$  (C)  $\frac{2}{3}$  (D)  $\frac{6}{7}$

Ans. B

Sol. Required probability =  $\frac{\text{ar}(ADEC)}{\text{ar}(ABC)}$

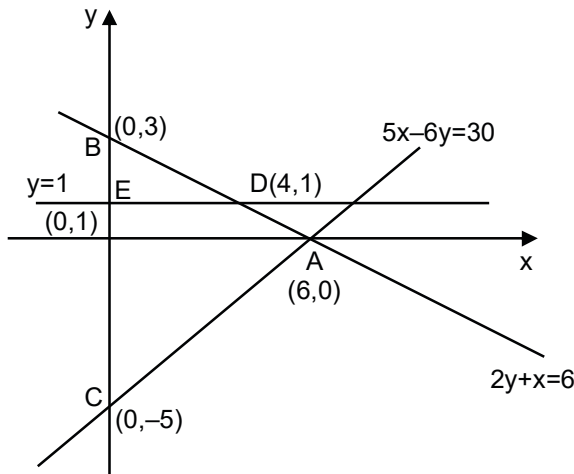

$$= 1 - \frac{\text{ar}(BDE)}{\text{ar}(ABC)}$$

$$= 1 - \frac{\frac{1}{2} \times 2 \times 4}{\frac{1}{2} \times 8 \times 6} = 1 - \frac{1}{6} = \frac{5}{6}$$

18. The value of  $\cot\left(\sum_{n=1}^{50} \tan^{-1}\left(\frac{1}{1+n+n^2}\right)\right)$  is
- (A)  $\frac{26}{25}$                       (B)  $\frac{25}{26}$                       (C)  $\frac{50}{51}$                       (D)  $\frac{52}{51}$

Ans. A

Sol.  $\tan^{-1} \frac{1}{1+n+n^2} = \tan^{-1} \left( \frac{(n+1) - n}{1+n(n+1)} \right)$

$$= \tan^{-1}(n+1) - \tan^{-1} n$$

so,  $\sum_{n=1}^{50} (\tan^{-1}(n+1) - \tan^{-1} n)$

$$= \tan^{-1} 51 - \tan^{-1} 1$$

$$\cot\left(\sum_{n=1}^{50} \tan^{-1}\left(\frac{1}{1+n+n^2}\right)\right) = \cot(\tan^{-1} 51 + \tan^{-1} 1)$$

$$= \frac{1}{\tan(\tan^{-1} 51 + \tan^{-1} 1)} = \frac{1+51 \times 1}{51-1} = \frac{52}{50} = \frac{26}{25}$$

19.  $\alpha = \sin 36^\circ$  is a root of which of the following equation
- (A)  $10x^4 - 10x^2 - 5 = 0$                       (B)  $16x^4 + 20x^2 - 5 = 0$   
 (C)  $16x^4 - 20x^2 + 5 = 0$                       (D)  $16x^4 - 10x^2 + 5 = 0$

Ans. C

Sol.  $\cos 72^\circ = \frac{\sqrt{5}-1}{4}$

$$\Rightarrow 1 - 2\sin^2 36^\circ = \frac{\sqrt{5}-1}{4}$$

$$\Rightarrow 4 - 8\alpha^2 = \sqrt{5} - 1$$

$$\Rightarrow 5 - 8\alpha^2 = \sqrt{5}$$

$$\Rightarrow (5 - 8\alpha^2)^2 = 5$$

$$\Rightarrow 25 + 64\alpha^4 - 80\alpha^2 = 5$$

$$\Rightarrow 64\alpha^4 - 80\alpha^2 + 20 = 0$$

$$\Rightarrow 64\alpha^4 - 20\alpha^2 + 5 = 0$$

20. Which of the following statement is a tautology ?

(A)  $((\sim q) \wedge p) \vee q$

(B)  $((\sim q) \wedge p) \wedge (p \wedge (\sim p))$

(C)  $((\sim q) \wedge p) \vee (p \vee (\sim p))$

(D)  $(p \wedge q) \wedge (\sim(p \wedge q))$

Ans. B

Sol. (A)  $(\sim q \wedge p) \wedge q = (\sim q \wedge q) \wedge p = f$

(B)  $(\sim q \wedge p) \wedge (p \wedge \sim p) = \sim q \wedge (p \wedge \sim p) = f$

(C)  $(\sim q \wedge p) \vee (p \wedge \sim p) = (\sim q \wedge p) \vee (t) = f$

(D)  $(p \wedge q) \wedge (\sim(p \wedge q)) = f$

SECTION-B

1. Let  $S = \{1, 2, 3, 4, 5, 6, 7, 8, 9, 10\}$ . Define  $f : S \rightarrow S$  as

$$f(n) = \begin{cases} 2n, & \text{if } n = 1, 2, 3, 4, 5 \\ 2n - 11 & \text{if } n = 6, 7, 8, 9, 10 \end{cases}$$

Let  $g : S \rightarrow S$  be a function such that  $f \circ g(n) = \begin{cases} n+1 & \text{, if } n \text{ is odd} \\ n-1 & \text{, if } n \text{ is even} \end{cases}$ , then  $g(10) \cdot (g(1) + g(2) + g(3) + g(4) + g(5))$  is equal to :

Ans. 190

Sol.  $f^{-1}(n) = \begin{cases} \frac{n}{2} & ; n = 2, 4, 6, 8, 10 \\ \frac{n+11}{2} & ; n = 1, 3, 5, 7, 9 \end{cases}$

$$f(g(n)) = \begin{cases} n+1 & ; n \in \text{odd} \\ n-1 & ; n \in \text{even} \end{cases}$$

$$\Rightarrow g(n) = \begin{cases} f^{-1}(n+1) & ; n \in \text{odd} \\ f^{-1}(n-1) & ; n \in \text{even} \end{cases}$$

$$\therefore g(n) = \begin{cases} \frac{n+1}{2} & ; n \in \text{odd} \\ \frac{n+10}{2} & ; n \in \text{even} \end{cases}$$

$$g(10) \cdot [g(1) + g(2) + g(3) + g(4) + g(5)] = 10 \cdot [1 + 6 + 2 + 7 + 3] = 190$$

2. Let  $\alpha, \beta$  be the roots of the equation  $x^2 - 4\lambda x + 5 = 0$  and  $\alpha, \gamma$  be the roots of the equation

$$x^2 - (3\sqrt{2} + 2\sqrt{3})x + 7 + 3\lambda\sqrt{3} = 0. \text{ If } \beta + \gamma = 3\sqrt{2}, \text{ then } (\alpha + 2\beta + \gamma)^2 \text{ is equal to :}$$

Ans. 98

Sol.  $x^2 - 4\lambda x + 5 = 0 \left\langle \begin{matrix} \alpha \\ \beta \end{matrix} \right.$   
 $x^2 - (3\sqrt{2} + 2\sqrt{3})x + (7 + 3\lambda\sqrt{3}) = 0 \left\langle \begin{matrix} \alpha \\ \gamma \end{matrix} \right.$

$$\alpha + \beta = 4\lambda$$

$$\alpha + \gamma = 3\sqrt{2} + 2\sqrt{3}$$

$$\beta + \lambda = 3\sqrt{2} \qquad \alpha\gamma = 7 + 3\lambda\sqrt{3}$$

$$\therefore \alpha = 2\lambda + \sqrt{3} \qquad \alpha\beta = 5$$

$$\beta = 2\lambda - \sqrt{3} \qquad 4\lambda^2 = 8 \Rightarrow \lambda = \sqrt{2}$$

$$\therefore (\alpha + 2\beta + \lambda)^2 = (4\alpha + 3\sqrt{2})^2 = (7\sqrt{2})^2 = 98$$

3. Let A be a matrix of order  $2 \times 2$ , whose entries are from the set  $\{0, 1, 2, 3, 4, 5\}$ . If the sum of all the entries of A is a prime number  $p$ ,  $2 < p < 8$ , then the number of such matrices A is :

Ans. 180

Sol. Let  $A = \begin{bmatrix} a & b \\ c & d \end{bmatrix}; a, b, c, d \in \{0, 1, 2, 3, 4, 5\}$

$$a + b + c + d = p, p \in \{3, 5, 7\}$$

Case-(i)

$$a + b + c + d = 3; a, b, c, d \in \{0, 1, 2, 3\}$$

$$\text{No. of ways} = {}^{3+4-1}C_{4-1} = {}^6C_3 = 56 \dots\dots\dots (1)$$

Case-(ii)

$$a + b + c + d = 5; a, b, c, d \in \{0, 1, 2, 3, 4, 5\}$$

$$\text{No. of ways} = {}^{5+4-1}C_{4-1} = {}^8C_3 = 56 \dots\dots\dots (2)$$

Case-(iii)

$$a + b + c + d = 7$$

No. of ways = total ways when  $a, b, c, d \in \{0, 1, 2, 3, 4, 5, 6, 7\}$  – total ways when  $a, b, c, d \notin \{6, 7\}$

$$\text{No of ways} = {}^{7+4-1}C_{4-1} = \left( \binom{4}{3} + \binom{4}{2} \right)$$

$$= {}^{10}C_3 - 16 = 104 \dots\dots\dots (3)$$

Hence total no. of ways = 180

4. If the sum of the coefficients of all positive powers of x, in the binomial of  $\left(x^n + \frac{2}{x^5}\right)^7$  is 939, then

the sum of all the possible integral values of n is :

Ans. 57

Sol. coefficients and there cumulative sum are :

Coefficient	Commulative sum
$x^{7n} \rightarrow {}^7C_0$	1
$x^{6n-5} \rightarrow 2 \cdot {}^7C_1$	1 + 14
$x^{5n-10} \rightarrow 2^2 \cdot {}^7C_2$	1 + 14 + 84
$x^{4n-15} \rightarrow 2^3 \cdot {}^7C_3$	1 + 14 + 84 + 280
$x^{3n-20} \rightarrow 2^4 \cdot {}^7C_4$	1 + 14 + 84 + 280 + 560 = 939
$x^{2n-25} \rightarrow 2^5 \cdot {}^7C_4$	

$$3n - 20 \geq 0 \cap 2n - 25 < 0 \cap n \in \mathbb{I}$$

$$\therefore 7 \leq n \leq 12$$

$$\text{Sum} = 7 + 8 + 9 + 10 + 11 + 12 = 57$$

5. Let  $\{t\}$  denote the greatest integer  $\leq t$  and  $\{t\}$  denote the fractional part of t. The integral value of  $\alpha$

for which the left hand limit of the function  $f(x) = [1+x] + \frac{\alpha^{2\{x\} + \{x\}} + [x] - 1}{2[x] + \{x}}$  at  $x = 0$  is equal to  $\alpha - \frac{4}{3}$

is \_\_\_\_\_

Ans. 3

Sol.  $f(x) = [1+x] + \frac{\alpha^{2\{x\} + \{x\}} + [x] - 1}{2[x] + \{x}}$

$$\lim_{x \rightarrow 0^-} f(x) = \alpha - \frac{4}{3} \Rightarrow 0 + \frac{\alpha^{-1} \cdot 2}{-1} = \alpha - \frac{4}{3}$$

$$\Rightarrow 2 - \frac{1}{\alpha} = \alpha - \frac{4}{3}$$

$$\Rightarrow \alpha + \frac{1}{\alpha} = \frac{10}{3}$$

$$\Rightarrow \alpha = 3; \alpha \in \mathbb{I}$$

6. If  $y(x) = (x^x), x > 0$  then  $\frac{d^2x}{dy^2} + 20$  at  $x = 1$  is equal to :

Ans. 16

Sol.

$$y = (x)^x$$

$$\ln y(x) = x^2 \cdot \ln x$$

$$\frac{1}{y(x)} \cdot y'(x) = \frac{x^2}{x} + 2x \cdot \ln x$$

$$y'(x) = y(x) [x + 2x \ln x]$$

$$y(1) = 1; y'(1) = 1$$

$$y''(x) = y'(x) [x + 2x \ln(x)]$$

$$+ y(x) [1 + 2(1 + \ln x)]$$

$$y''(1) = 1 [1 + 0] + 1 (1 + 2) = 4$$

$$\frac{d^2y}{dx^2} = -\left(\frac{dy}{dx}\right)^3 \cdot \frac{d^2x}{dy^2}$$

$$\Rightarrow 4 = -\frac{d^2x}{dy^2}$$

$$\frac{d^2x}{dy^2} = -4$$

7. If the area of the region  $\{(x, y) : x^{\frac{2}{3}} + y^{\frac{2}{3}} \leq 1, x + y \geq 0, t \geq 0\}$  is A, then  $\frac{256A}{\pi}$  is

Ans. 36

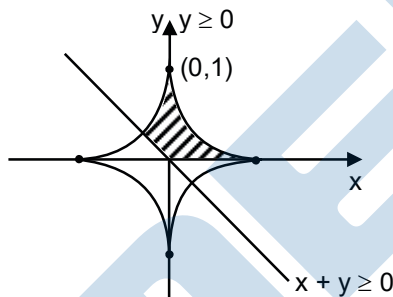

$$A = \frac{3}{2} \int_0^1 (1 - x^{2/3})^{3/2} dx$$

Let  $x = \sin^3 \theta$

$$A = \frac{3}{2} \int_0^{\pi/2} (1 - \sin^2 \theta)^{3/2} \cdot 3 \sin^2 \theta \cos \theta d\theta$$

$$= \frac{3}{2} \int_0^{\pi/2} 3 \sin^2 \theta \cos^4 \theta d\theta$$

$$= \frac{9}{2} \int_0^{\pi/2} \sin^2 \theta \cos^4 \theta d\theta$$

$$A = \frac{9}{2} \times \frac{1.3.1}{(2+4)(4)(2)} \cdot \frac{\pi}{2}$$

$$\Rightarrow A = \frac{9\pi}{64} \Rightarrow \frac{64A}{\pi} = 9$$

$$\Rightarrow \frac{256A}{\pi} = 36.$$

8. Let  $v$  be the solution of the differentiable equation  $(1 - x^2) dy = (xy + (x^3 + 2)\sqrt{1 - x^2}) dx, -1 < x < 1$

and  $y(0) = 0$  if  $\int_{-\frac{1}{2}}^{\frac{1}{2}} \sqrt{1 - x^2} y(x) dx = k$  then  $k^{-1}$  is equal to :

Ans. 320

Sol.  $(1 - x^2) \frac{dy}{dx} = xy + (x^3 + 2)\sqrt{1 - x^2}$

$$\Rightarrow \frac{dy}{dx} + \left( \frac{-x}{1 - x^2} \right) y = \frac{x^3 + 2}{\sqrt{1 - x^2}}$$

$$IF = e^{\int \frac{-x}{1 - x^2} dx} = \sqrt{1 - x^2}$$

$$y(x) \cdot \sqrt{1 - x^2} = \frac{x^4}{4} + 2x + c$$

$$y(0) = 0 \Rightarrow c = 0$$

$$\sqrt{1 - x^2} y(x) = \frac{x^4}{4} + 2x$$

$$\text{Required value} = \int_{-\frac{1}{2}}^{\frac{1}{2}} \left( \frac{x^4}{4} + 2x \right) dx - \frac{1}{4} \cdot 2 \int_0^{\frac{1}{2}} x^4 dx = \frac{1}{10} (x^5)_0^{\frac{1}{2}} = \frac{1}{320}$$

$$k^{-1} = 320$$

9. Let a circle  $C$  of radius 5 lie below the  $x$ -axis. The line  $L_1 = 4x + 3y - 2$  passes through the centre  $P$  of the circle  $C$  and intersects the line  $L_2: 3x - 4y - 11 = 0$  at  $Q$ . The line  $L_2$  touches  $C$  at the point  $Q$ . Then the distance of  $P$  from the line  $5x - 12y + 51 = 0$  is

Ans. 11

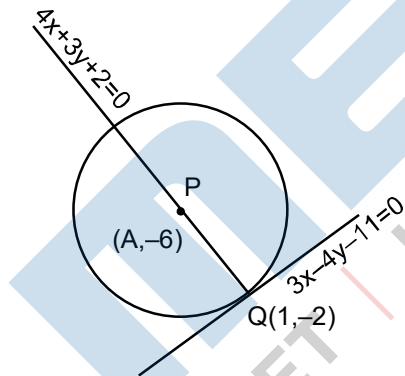

Sol.

$$4x + 3y + 2 = 0$$

$$3x - 4y - 11 = 0$$

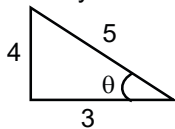

$$\frac{x}{-25} = \frac{y}{50} = \frac{1}{-25}$$

$$\frac{x - 1}{\cos \theta} = \frac{y + 2}{\sin \theta} = \pm 5$$



$$y = -2 + 5\left(-\frac{4}{5}\right) = -6$$

$$x = 1 + 5\left(\frac{3}{5}\right) = 4$$

Req. distance

$$\frac{|5(4) - 12(-6 + 51)|}{13}$$

$$= \frac{|20 + 72 + 51|}{13}$$

$$= \frac{143}{13} = 11$$

10. Let  $S = \{E, E_2, \dots, E_8\}$  be a sample space of random experiment such that  $P(E_n) = \frac{n}{36}$  for every  $n = 1, 2, \dots, 8$ . Then the number of element in the set  $\{A \subset S : P(A) \geq \frac{4}{5}\}$  is \_\_\_\_\_

Ans. 19

Sol.  $P(A') < \frac{1}{5} = \frac{36}{180}$

5 times the sum of missing number should be less than 36.

If 1 digit is missing = 7

If 2 digit is missing = 9

If 3 digit is missing = 2

If 0 digit is missing = 1

**Alternate**

A is subset of S here

A can have element :

Type 1 : { }

Type2 : {E<sub>1</sub>}, {E<sub>2</sub>}, .....{E<sub>8</sub>}

Type3 : {E<sub>1</sub>, E<sub>2</sub>}, {E<sub>1</sub>, E<sub>3</sub>}, .....{E<sub>1</sub>, E<sub>8</sub>}

⋮

⋮

Type6 : {E<sub>1</sub>, E<sub>2</sub>, .....E<sub>5</sub>}, .....{E<sub>4</sub>, E<sub>5</sub>, E<sub>6</sub>, E<sub>7</sub>, E<sub>8</sub>}

Type7 : {E<sub>1</sub>, E<sub>2</sub>, .....E<sub>6</sub>}, .....{E<sub>3</sub>, E<sub>4</sub>, ..... E<sub>8</sub>}

Type8 : {E<sub>1</sub>, E<sub>2</sub>, .....E<sub>7</sub>} {E<sub>2</sub>, E<sub>3</sub>, ..... E<sub>8</sub>}

Type9 : {E<sub>1</sub>, E<sub>2</sub>, .....E<sub>8</sub>}

$$\text{As } P(A) \geq \frac{4}{5};$$

Note : Type 1 to Type 4 element can not be in set A as maximum probability of type 4 elements.

$$\{E_5, E_6, E_7, E_8\} \text{ is } \frac{5}{36} + \frac{6}{36} + \frac{7}{36} + \frac{8}{36} = \frac{13}{18} < \frac{4}{5}$$

Now for Type 5 acceptable elements let's call probability as P<sub>5</sub>

$$P_5 = \frac{n_1 + n_2 + n_3 + n_4 + n_5}{36} \leq \frac{4}{5}$$

$$\Rightarrow n_1 + n_2 + n_3 + n_4 + n_5 \geq 28.8$$

Hence, 2 possible ways {E<sub>5</sub>, E<sub>6</sub>, E<sub>7</sub>, E<sub>8</sub>, E<sub>3</sub> or E<sub>4</sub>}

$$P_6 = n_1 + n_2 + n_3 + n_4 + n_5 + n_6 \geq 28.8$$

⇒ 9 possible ways

$$P_7 \Rightarrow n_1 + n_2 + \dots + n_7 \geq 28.8$$

⇒ 7 possible ways

$$P_8 \Rightarrow n_1 + n_2 + \dots + n_8 \geq 28.8$$

⇒ 1 possible way

Total = 19